



Sprinter MY2019 - Sensors vs paint

Technical Bulletin 907-34

EVS Charleston

6/13/2018

Mercedes-Benz Vans, LLC

Mercedes-Benz



Notice

Mercedes-Benz Vans, LLC does not warrant the accuracy of the information contained in this bulletin and reserves the right to modify or append this bulletin without prior notification. Mercedes-Benz disclaims all liability associated with the provision of this bulletin.

This bulletin is not intended to serve as a work instruction, but merely to provide some helpful information for upfitters to take into consideration before retrofitting or modifying a Mercedes-Benz or Freightliner Sprinter.

Prior to making any modification to or installing any equipment in or on a Mercedes-Benz or Freightliner Sprinter, you should review and insure compliance with all applicable laws and regulations, consult with Vans Engineering Support for Upfitter Management for additional and updated information, and read the Body & Equipment Guidelines for Sprinter Model Series 907.

Upfitter Management Vans Contacts:

For information or upfitter inquiries
please submit a request via our website:

www.upfitterportal.com

Sprinter MY2019+ – Sensors vs paint

Introduction

The “Parktronic”-, “Collision Prevent Assist”- and “Blind Spot Assist”- sensors are located inside and behind the plastic bumpers of the vehicle. Bumpers, which get painted or repainted by the Upfitters, especially in the area, which might affect the radar signal of the sensors, have to comply with Mercedes-Benz standards. This bulletin will show the locations of the sensor affecting areas and will give a paint recommendation regarding version and thickness.

Front bumper

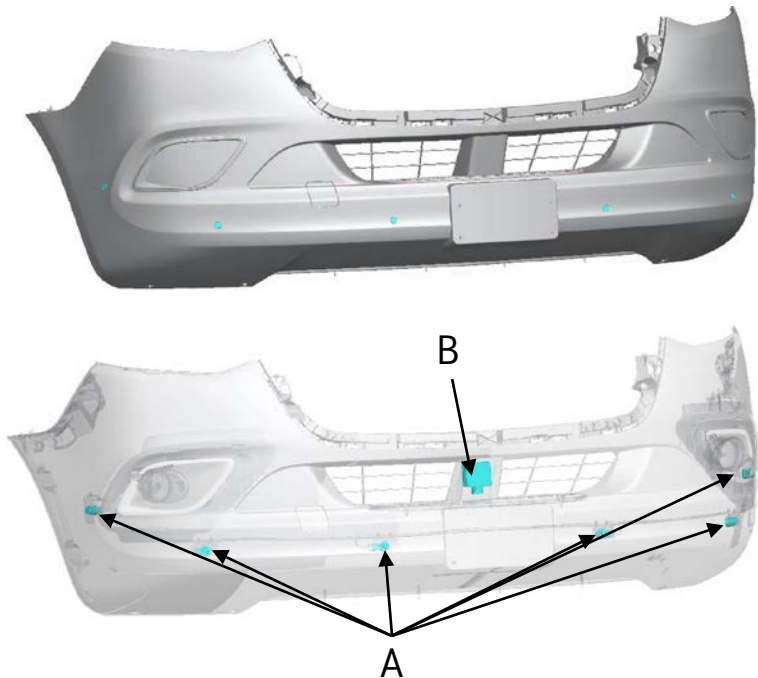

Mercedes-Benz

Rear bumper

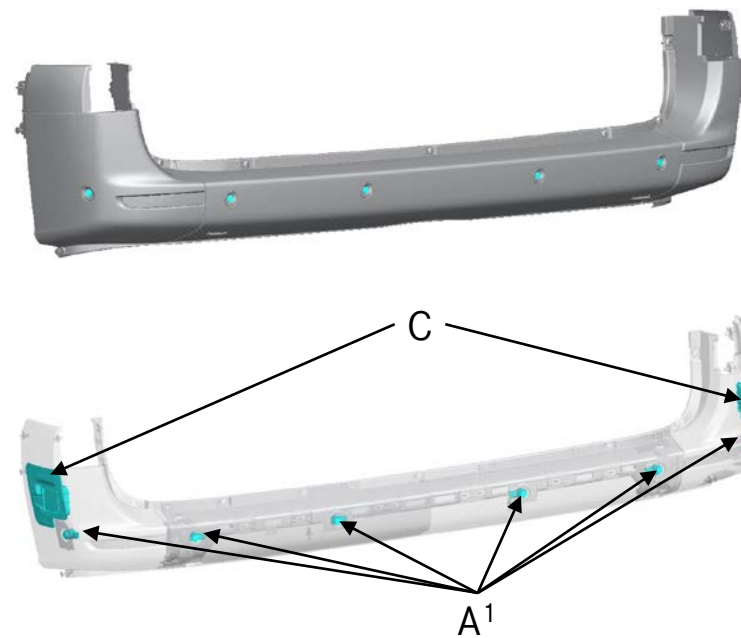

¹ In case of a step at the rear bumper, the sensors of the Parking Package are located in the step

	Sensor	Quantity front bumper	Quantity rear bumper
A	Parking Package	6	6
B	Active Brake Assist / Active Distance Assist	1	0
C	Blind Spot Assist	0	2

Sprinter MY2019+ – Sensors vs paint

BEG Information

Among other things, radar sensors are sensitive to:

- the thickness of the paint layers
- the relative permittivity of the paint
- the amount of conductive materials in the paint (e. g. metals, graphite, etc.)

The higher the thickness of the paint layers, the relative paint permittivity, or the amount of conductive materials in the paint, the more the functionality of the sensors is affected.



Warning

Depending on the version and thickness, paints or film coating may absorb radar signals. This may lead to malfunction or system failure. The driver could lose control of the vehicle and cause an accident.

Mask the following areas before painting:

- Sealing surfaces
- Windows
- Contact areas between wheels and wheel hubs
- Contact areas for wheel nuts
- Vents on transmission, axles, etc.
- Disc brakes
- Door Locks
- Door retainers in the rear door hinges
- Contact surfaces on the guide rails for the sliding doors
- Door retainers and opening limiters in the center guide rails
- Moving parts of the sliding door carriage
- Airbags and seat belts
- Parktronic sensors (→ Chapter 7.9.8)
- Collision Prevention Assist sensor
- Blind Spot Assist sensor

Sprinter MY2019+ – Sensors vs paint Requirements

Available codes:

Painted bumpers ex-factory:

- Code CM0: painted metallic front and rear bumper

Primed bumpers ex-factory:

- Code C72: bumper front / rear primed
- Code CM9: primed side moldings

Recommended paint brands:

- OEM paints only
- USA: Glasurit, R-M, Standox, Spies Hecker, PPG
- Canada: Glasurit, R-M, Standox

Requirements for unpainted / primed bumpers:



Thickness limitation for metallic paint:

- **max. 15µm of paint + 1 layer of clear coat**

Thickness limitation non metallic paint:

- **no constraints**

Requirements for repainting bumpers:



In case of repainting the bumpers / side moldings, make sure to remove the top layer of paint in the area of the sensors by grinding. Then, comply with the following requirements showed above.

Sprinter MY2019+ – Sensors vs paint

Detailed view front bumper

Front view

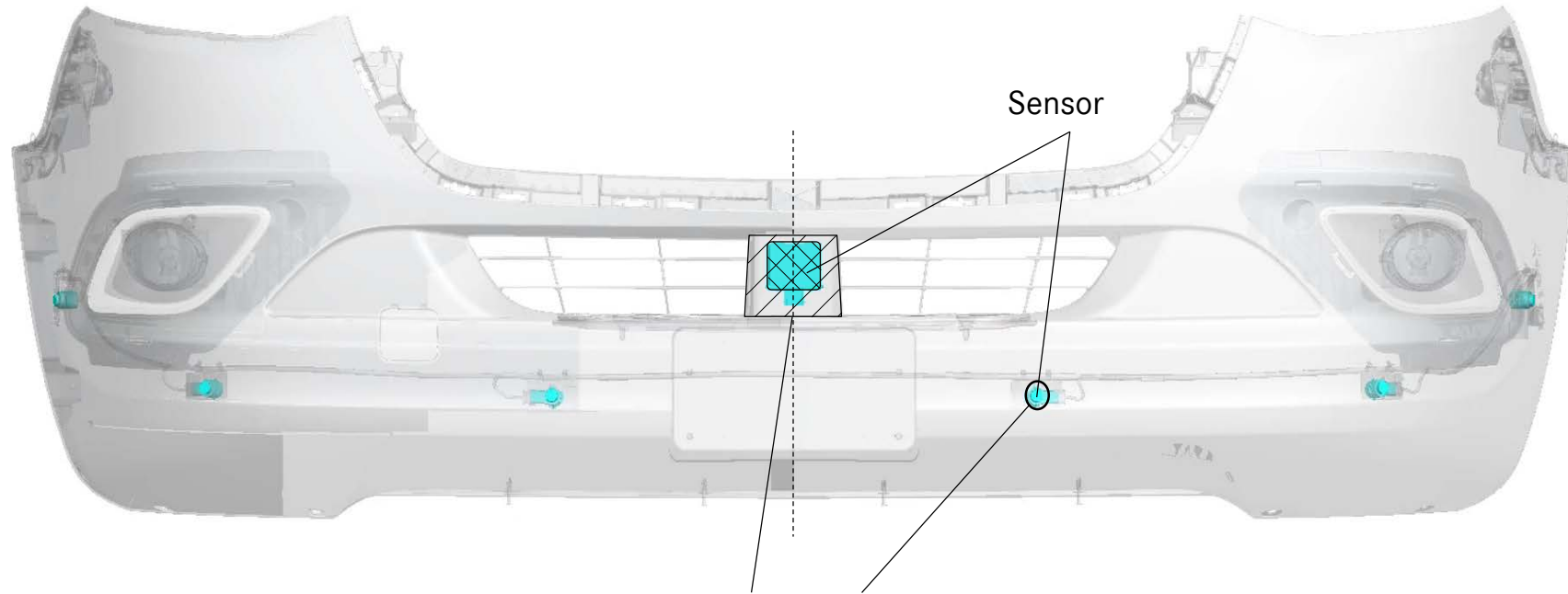

Sensors affected by paint
in this area



(as well as the other blue
marked areas/sensors)

Sprinter MY2019+ – Sensors vs paint

Detailed view rear bumper

Side view

