



# MY2023/24 Sprinter – Installation of Blind Spot Sensor (J1V) Technical Bulletin

Version 5/22/2024  
Mercedes-Benz Vans, LLC

Mercedes-Benz



# Notice

Mercedes-Benz USA, LLC does not warrant the accuracy of the information contained in this bulletin and reserves the right to modify or append this bulletin without prior notification. Mercedes-Benz disclaims all liability associated with the provision of this bulletin.

This bulletin is not intended to serve as a work instruction, but merely to provide some helpful information for upfitters to take into consideration before retrofitting or modifying a Mercedes-Benz or Freightliner Sprinter.

Prior to making any modification to or installing any equipment in or on a Mercedes-Benz or Freightliner Sprinter, you should review and ensure compliance with all applicable laws and regulations, consult with Upfitter Management Vans for additional and updated information, and read the Body & Equipment Guidelines (BEG) for Sprinter Model Series 907.

## Upfitter Management Vans Contacts:

For information or upfitter inquiries  
please submit a request via our website:

[www.upfitterportal.com](http://www.upfitterportal.com)

# MY2023/24 Sprinter – Installation of Blind Spot Sensor (J1V)

## Overview

Pre-installation of Blind Spot Sensor (code J1V) package includes:

- 2 Blind spot sensors
- 2 Plastic brackets
- 2 Covers
- 8 Screws (connect plastic bracket with cover)
- Wiring harness interface in the driver seat box

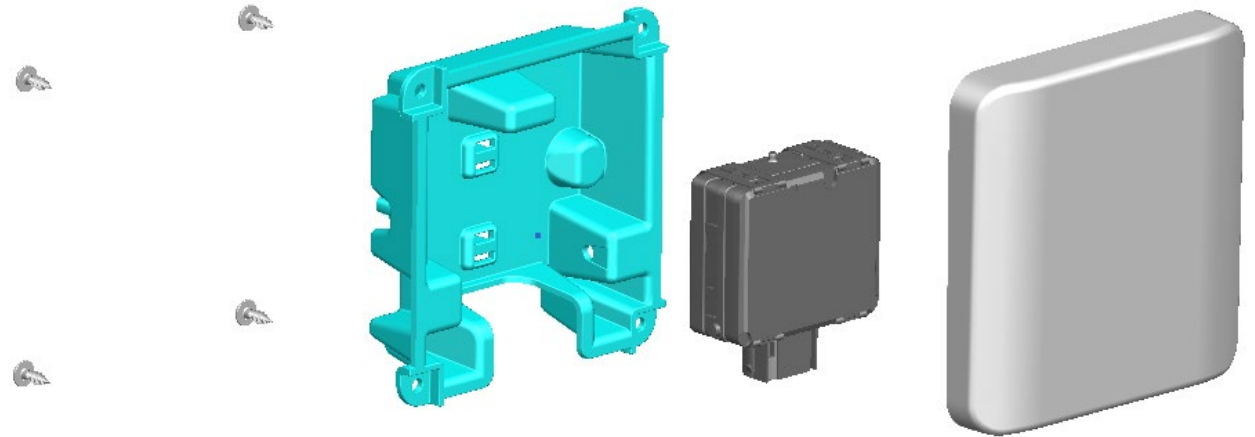

For more information,

- Visit Upfitter Portal ([www.UpfitterPortal.com](http://www.UpfitterPortal.com)) for 3D CAD data
- Review Sprinter Body and Equipment Guideline (BEG) section 8.9.4 ‘Blind Spot Assist/ Rear Cross Traffic Alert (RCTA)/ Exit Warning’

# MY2023/24 Sprinter – Installation of Blind Spot Sensor (J1V)

## Limit values for positioning the sensors

Measured from the reference point of the sensor, the blind spot sensor must be placed:

- At most 6250 mm from the wheel center of the front axle
- At most 1650 mm from rear end of vehicle body
- At least 350 mm from the ground
- At most 1000 mm from the ground

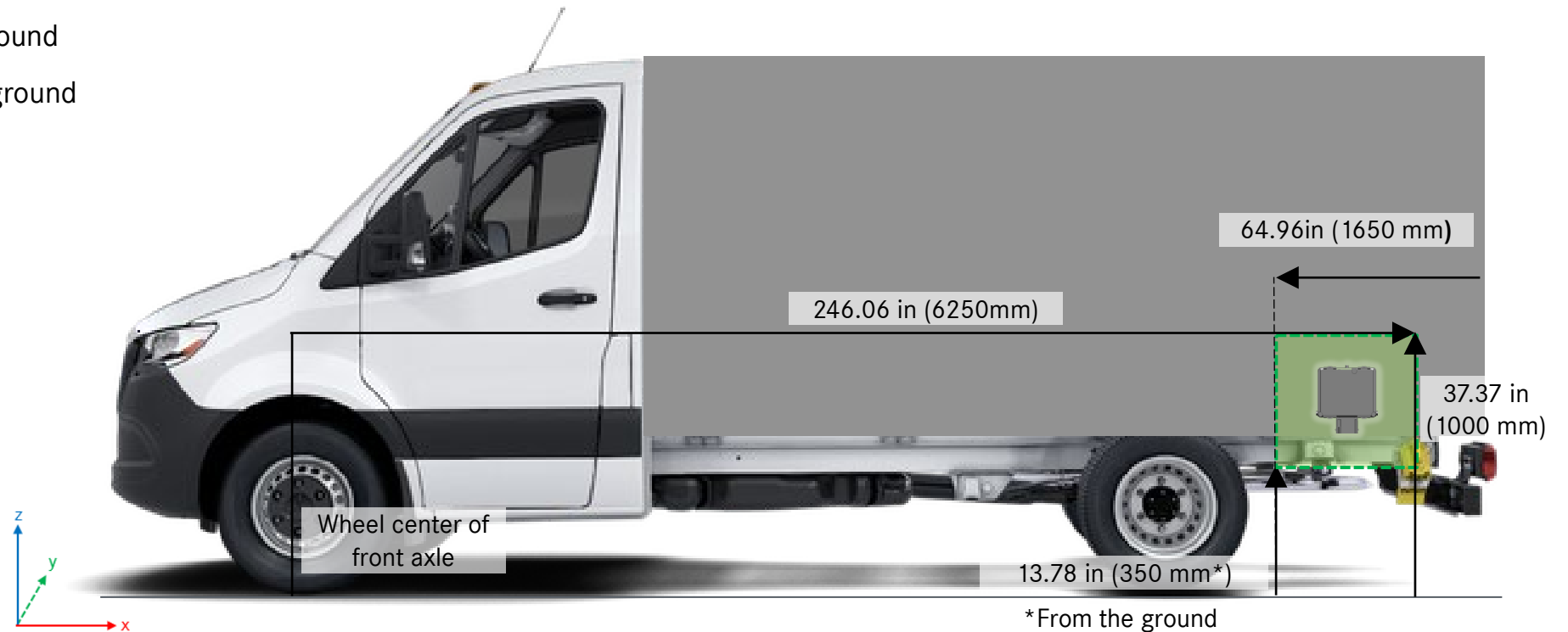
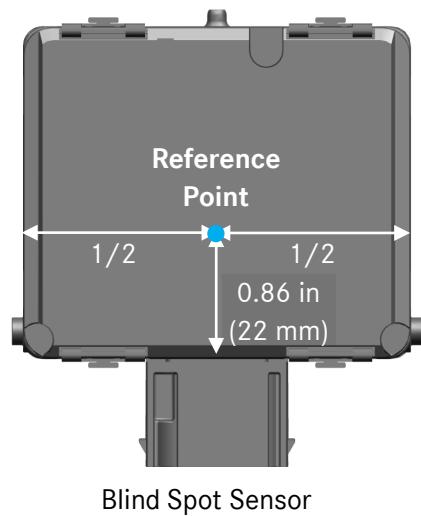

# MY2023/24 Sprinter – Installation of Blind Spot Sensor (J1V)

## Bracket & Mounting Information

Create a metal bracket for each side that holds the sensor at  $10.5^\circ \pm 1^\circ$  from the side wall:

- Surface that is angled at  $10.5^\circ \pm 1^\circ$  (e.g. metal bracket) must be mounted perpendicular ( $90^\circ \pm 1^\circ$ ) to the ground
- Bracket can be mounted outside the vehicle, or a cutout can be made allowing the sensor to be recessed into the outer panel of the vehicle
  - Cutout dimensions: approximately 5.9 in X 5.9 in (150 mm X 150 mm)
  - Rear side of cover must extend at least 0.08 in (2mm) from the outer panel

Mount the metal bracket with the sensor and cover to the side wall with protruding part facing the vehicle rear:

- Sensor plug must point downward

Protect against water intrusion and corrosion:

- Water drops should not fall onto the sensor as this could interfere with the sensor's ability to detect objects

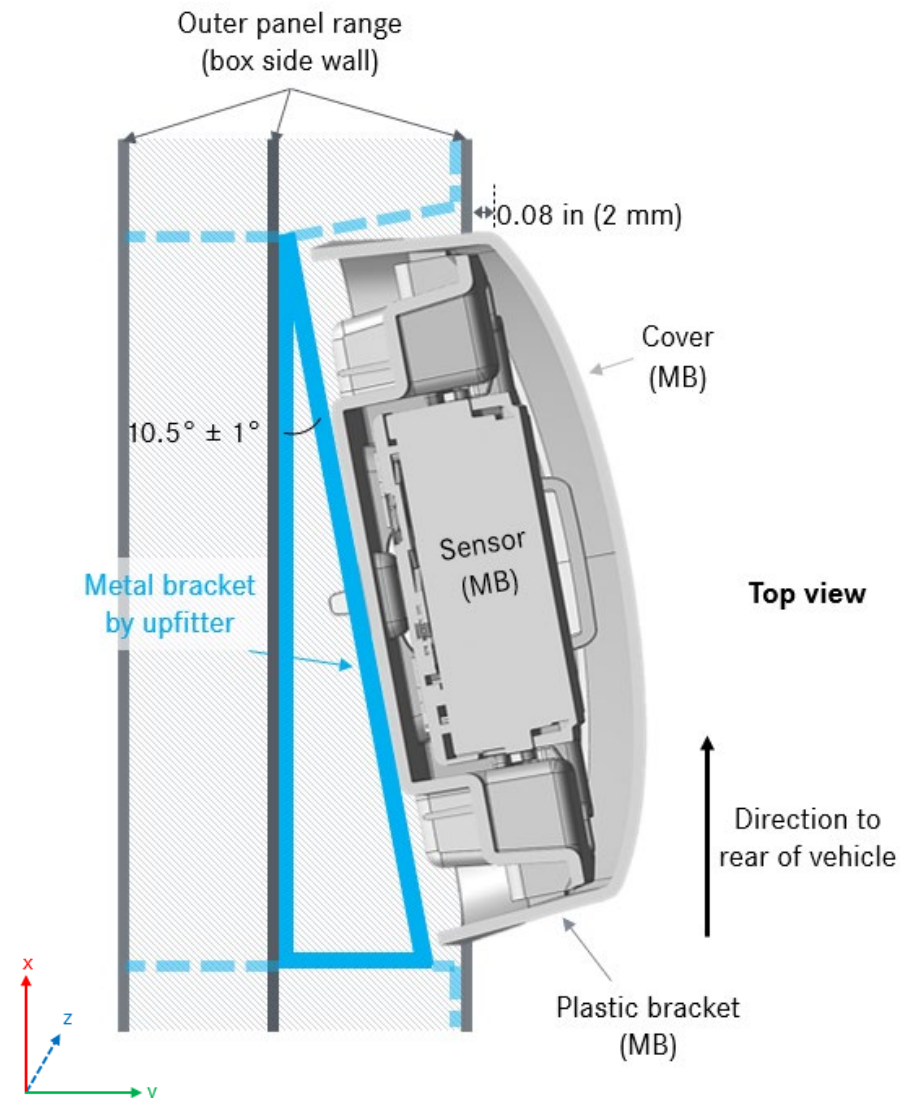

# MY2023/24 Sprinter – Installation of Blind Spot Sensor (J1V) Upfitter Bracket

The upfitters must design and manufacture their own bracket that will hold the blind spot sensor assembly and fit to the design and the layout of box body side wall. Following are the guidelines for designing the upfitter bracket:

- Ensure that the bracket is made from metal with 0.08 in (2 mm) thickness to allow the plastic bracket clips to pass through
- Include three threaded holes to fasten the metal bracket onto the Mercedes-Benz plastic bracket. Part number for screws is A0059907612.
- Include two small rectangular holes for clips from the Mercedes-Benz plastic bracket
- Include a gap at the bottom of the bracket for the wiring to the sensor to pass through
- Account for water drainage in the case any liquid leaks into the bracket assembly

For reference, an example design of the metal bracket is available on the Upfitter Portal. Please see under ‘3D CAD Data’ page.

## Example Design:

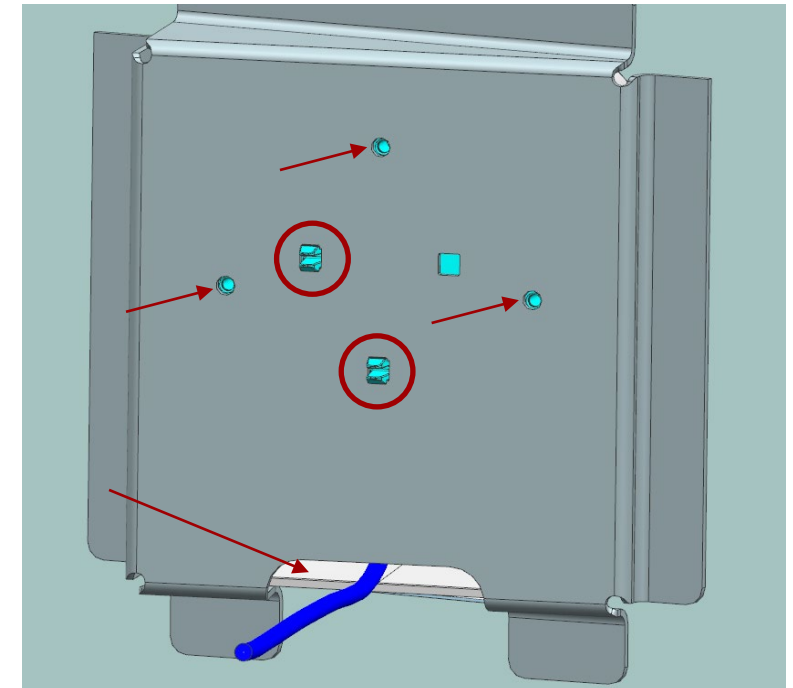

\*(Actual design may vary by upfitter)

# MY2023/24 Sprinter – Installation of Blind Spot Sensor (J1V)

## Assembly Instructions

1. Assemble all the ex-factory Mercedes-Benz parts together. Mount the sensor onto the plastic brackets and affix the plastic bracket to the plastic cover.



2. Mount the metal bracket designed by the upfitter on the box body side wall.

### Example:

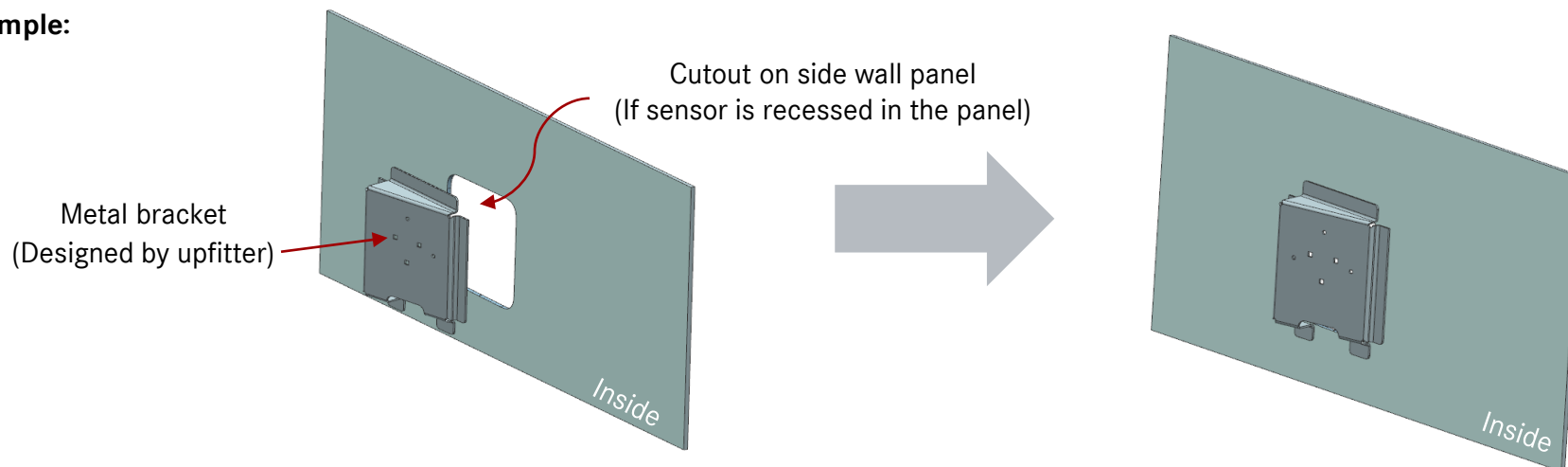

\*Note: Depending on upfitter design, the bracket may need to be mounted to the side wall after sensor installation.

# MY2023/24 Sprinter – Installation of Blind Spot Sensor (J1V)

## Assembly Instructions

3. Locate the mating connector to the sensor plug and cover the blind spot sensor wiring harnesses to protect against sharp edges and/or debris.
4. Slide the mating connector wiring through the metal bracket mounted on the side wall panel. Note that the wiring needs to go from inside of the side wall panel to the outside of the panel.
5. Connect the mating connector to the plug of the blind spot sensor located on the outer surface of the side wall panel. Note that the sensor plug should face down.

### Example:

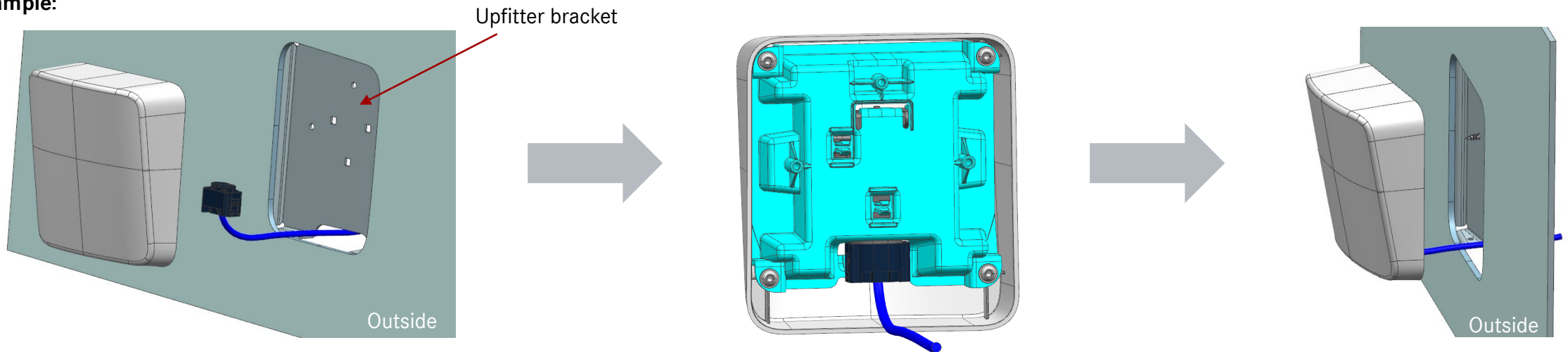



# MY2023/24 Sprinter – Installation of Blind Spot Sensor (J1V)

## Assembly Instructions/Section Views

- Fasten the blind spot sensor assembly to the metal bracket from inside the side panel.

Note that screws have tightening torque of  $1.6\text{Nm} \pm 0.2\text{Nm}$ .

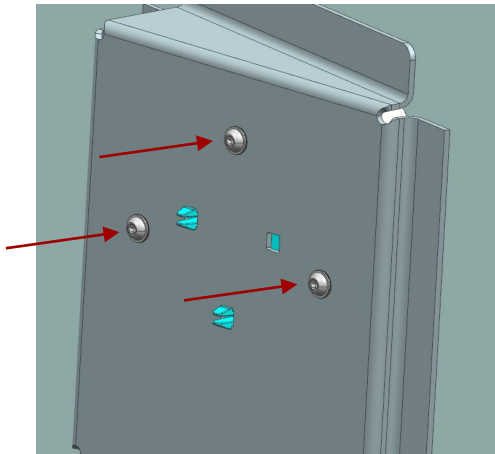

### Fully Assembled Views

Horizontal Cut (Top View)

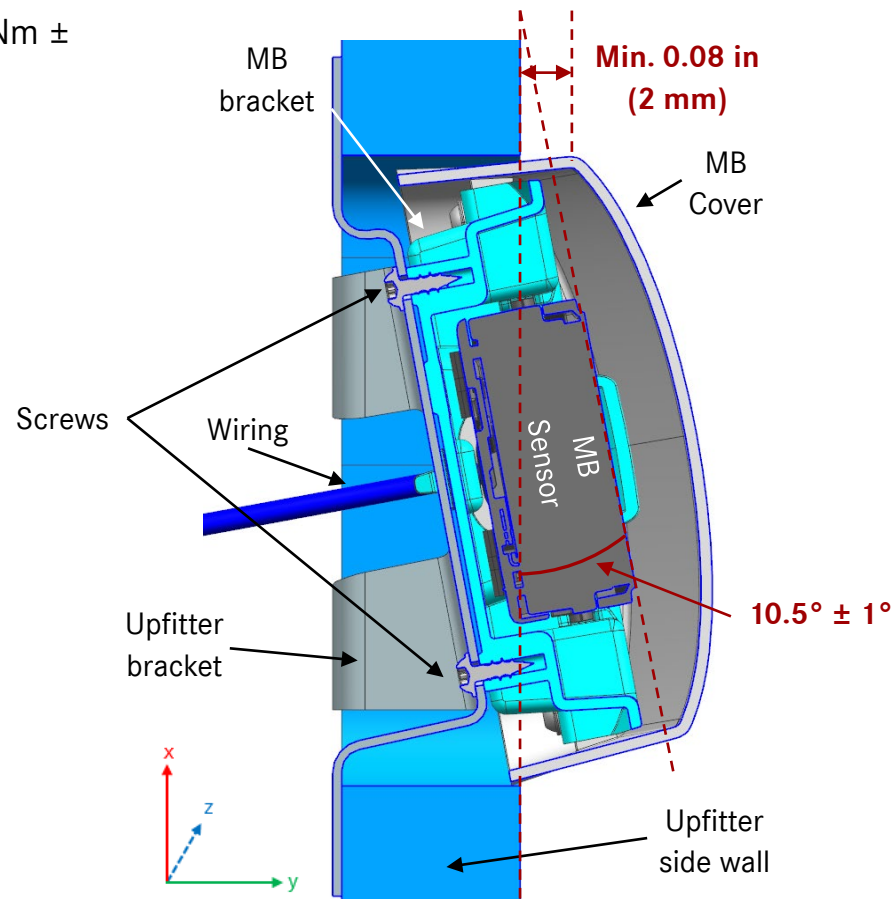

Vertical Cut

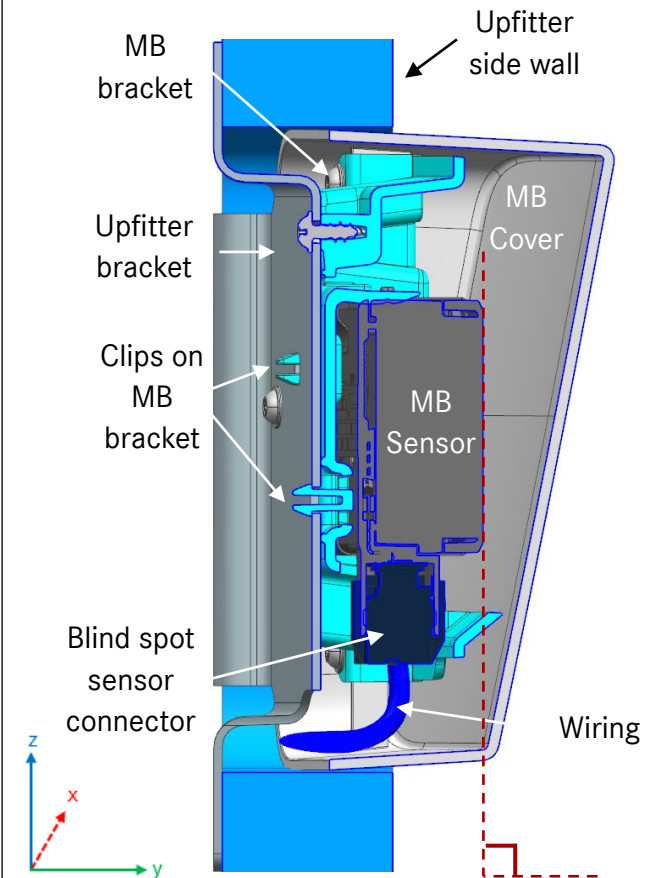

# MY2023/24 Sprinter – Installation of Blind Spot Sensor (J1V)

## Mounting Restrictions

Please observe the following requirements when installing the blind spot sensors:

- When installing and testing the blind spot sensors, ensure that the workplace and the workers are equipped with ESD protection. Without such protections, the sensors may be damaged by electrostatic discharges
- Blind spot sensors must be positioned symmetrically on the left and right-side wall panels.
- Do not install any additional cover to the provided ex-factory blind spot cover. Do not cover the blind spot sensor.
- Radar cone of the sensor must not touch the side wall. Radar cone is included in 3D CAD data for blind spot sensor.
- Top rear outer edge of the cover (see arrow) must be at least 0.08 in (2 mm) extruded out from the side wall outer-surface

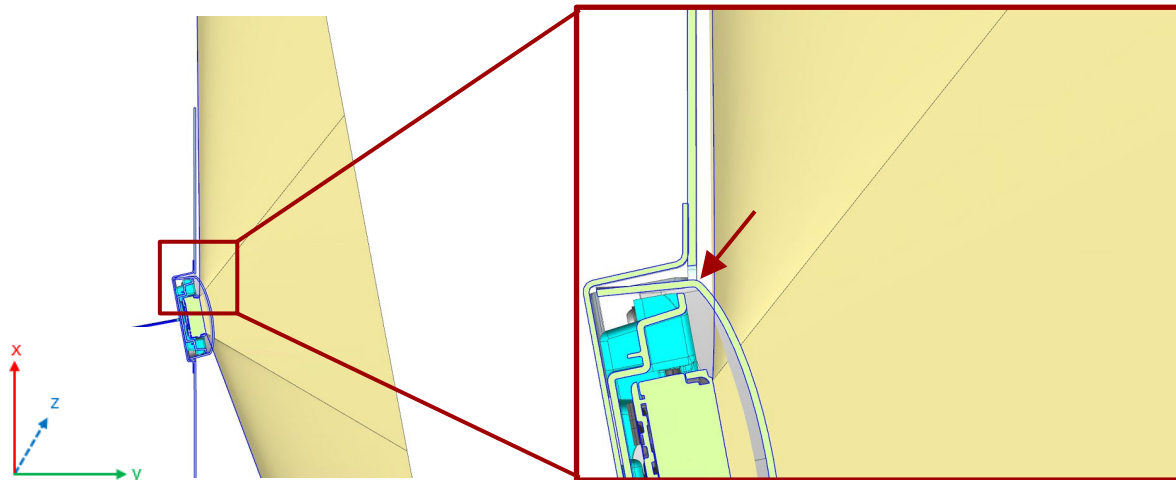

# MY2023/24 Sprinter – Installation of Blind Spot Sensor (J1V)

## Mounting Restrictions

Please observe the following requirements when installing the blind spot sensors:

- Do not mount blind spot sensor on moveable surfaces (e.g. storage doors, slide-outs). Blind spot sensor must be mounted on a surface that is rigidly fixed on the vehicle body.
- No parts must be inside the radar cone, especially metallic parts. Do not install any parts projecting out in the direct line between the sensor and the rear of the vehicle. Any extruding parts that are attached perpendicular (90°) to the side panel and/or have a rounded can reflect the rays from the blind spot sensor back to the sensor.
- No attachments protruding from the surface wall (e.g. door handles, signal lights) may be installed between the sensor and the rear of the vehicle at a vertical angle of  $\pm 20^\circ$  from the sensor reference point (see slide 4 for reference point position).
- No detachable parts may be mounted on the vehicle rear at area that is outside of  $10^\circ$  inward angle measured from at least 3.9 in (100 mm) into the side wall.

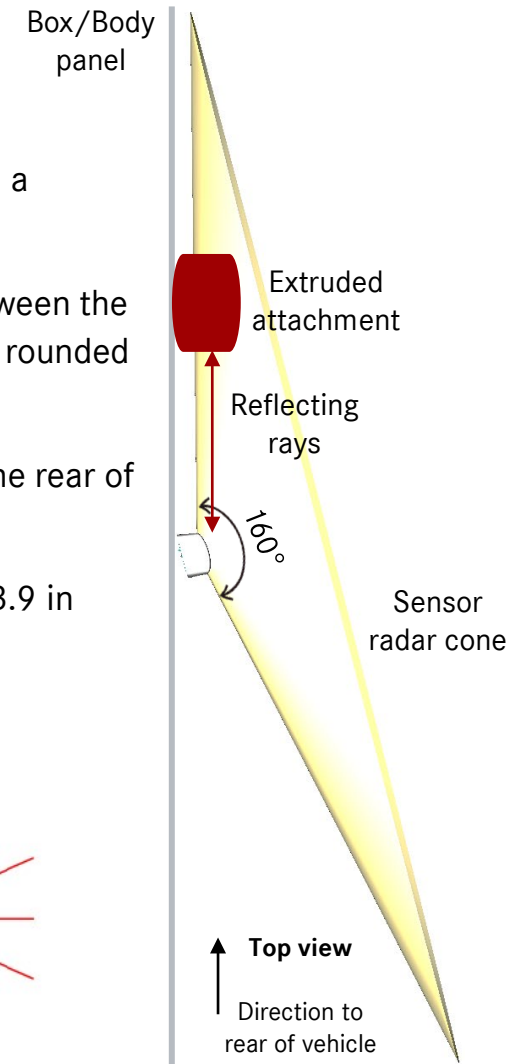
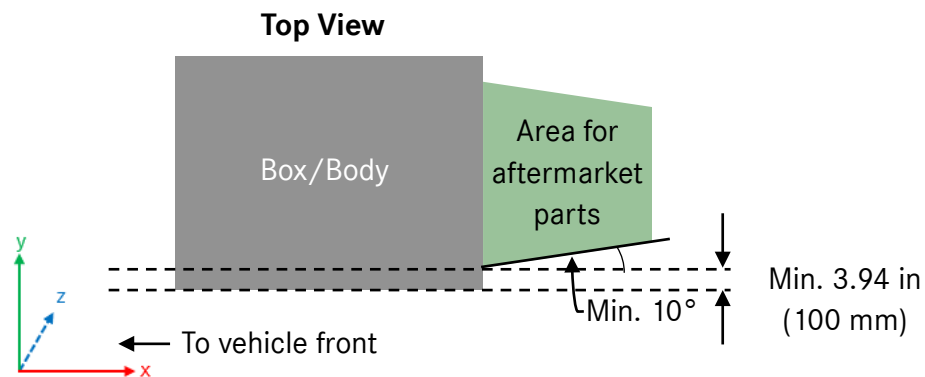

# MY2023/24 Sprinter – Installation of Blind Spot Sensor (J1V)

## Paint for Plastic Cover

The ex-factory plastic cover will be delivered unpainted, so that the upfitters can paint the plastic cover to match the outer side wall panel of their upfitted vehicles. Please note that the paint coat structure must not exceed the following limits:

Thickness limitation for metallic paint:

- max. 15  $\mu\text{m}/5.9\text{e-}4$  in of paint + 1 layer of clear coat

Thickness limitation non-metallic paint:

- max. 15  $\mu\text{m}/5.9\text{e-}4$  in of paint + 2 layers of clear coat

Paint brand requirements:

- Mercedes-Benz paints only
- USA: Glasurit, R-M, Standox, Spies Hecker, PPG
- Canada: Glasurit, R-M, Standox

The material thickness must be homogeneous to prevent distortion of the radar waves.

Specified thickness for unpainted covers: 0.098 in +/- 0.004 in (2.5 mm +/-0.1 mm), without paint

# MY2023/24 Sprinter – Installation of Blind Spot Sensor (J1V)

## Electrical Connection – Rear axle

Wiring harness for the blind spot sensor is located behind the rear axle. This includes the connector, shown below, that must connect to the blind spot sensor.

Upfitters must acquire their own extension wires based on the length of the upfitted vehicle. Using the extension wires, connect the blind spot sensor connector in the driver seat box to the blind spot sensor mounted at the rear of the vehicle.

### Vehicle Connector (Behind the rear axle)

### Mating Connector (Required for Upfitter wiring harness)

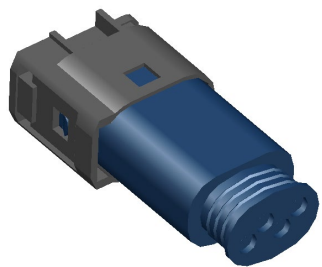

Pin	Connection	Color
1	Ignition (Terminal 15)	BK/YE
2	Peripherals CAN High	GN/WH
3	Peripherals CAN Low	GN
4	Ground (Terminal 31)	BN

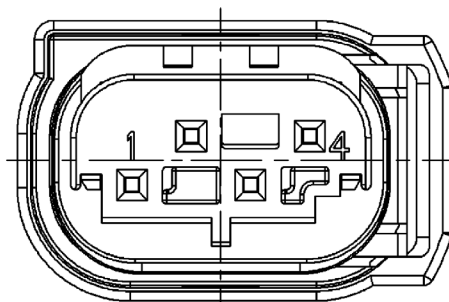

**Mating Connector:** A 210 540 49 81

Supplier “TE Connectivity”: 1-967584-1

**Contact pin:** A 026 545 71 28

Supplier “TE Connectivity”: 1394006 VERSION B

**Single seal:** A 000 545 69 80

Supplier “TE Connectivity”: 0-967067-1

(TE Connectivity = TYCO Electronics)

**Vehicle Connector:**  
A 210 540 43 81

# MY2023/24 Sprinter – Installation of Blind Spot Sensor (J1V)

## Electrical Connection - Sensor

The plug at the bottom of the blind spot sensor is shown below. Using extension wires, link the connector in the driver seat box to the connector on the blind spot sensor. The upfitter must protect the wires against sharp edges and/or debris.

Follow the pin information provided in the table when pinning to the sensor connector. Note that the wiring for the right-side sensor differs from the wiring for the left side sensor.

### Sensor Connector

(Sensor side)

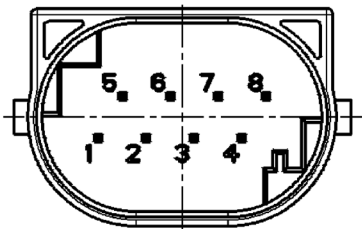

#### Sensor Connector:

A 907 900 60 04

Pin	Right Side Connector (Primary)	Left Side Connector (Secondary)
1	Ground (Terminal 31)	Ground (Terminal 31)
2	CAN High	CAN High
3	CAN Low	CAN Low
4	-	-
5	-	-
6	-	-
7	Ground (side detection)	-
8	Ignition (Terminal 15)	Ignition (Terminal 15)

### Mating Connector

(Required for Upfitter wiring harness)

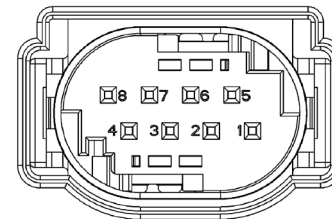

**Mating Connector:** A 210 540 45 81

Supplier “TE Connectivity”: 1-1418743-1

**Contact pin:** A 008 545 63 26

Supplier “TE Connectivity”: 929454

**Single seal:** A 000 545 69 80

Supplier “TE Connectivity”: 0-967067-1

**Blind plug:** A 000 545 87 80

Supplier “TE Connectivity”: 0-967056-1

(TE Connectivity = TYCO Electronics)

# MY2023/24 Sprinter – Installation of Blind Spot Sensor (J1V)

## Xentry – Software Coding

Once the blind spot sensors, use Xentry to activate blind spot sensor functions.

1. Add option code OB2 'Activation of Blind Spot Sensor' to VeDoc using Xentry.
2. Add appropriate O-codes based on the upfitted vehicle's dimensions for each of the following categories:
  - Rear overhang, Vehicle width without mirrors, Mounting height, Mounting x-distance to the rear axle
  - Please see Appendix for all the available relevant O-codes
3. Perform SCN coding on the following control modules:
  - B92/21 Outer right rear intelligent radar sensor system (IRS-HRA)
  - B92/24 Outer left rear intelligent radar sensor system (IRS-HLA)
  - N69/1 Driver side door control unit
  - N69/2 Passenger side door control unit

No calibrations needed after installation of blind spot sensor.

# Appendix



# MY2023/24 Sprinter – Installation of Blind Spot Sensor (J1V)

## Physical Specifications

**Hole patterns for the upfitter bracket:**  
Measurement and tolerances in millimeters

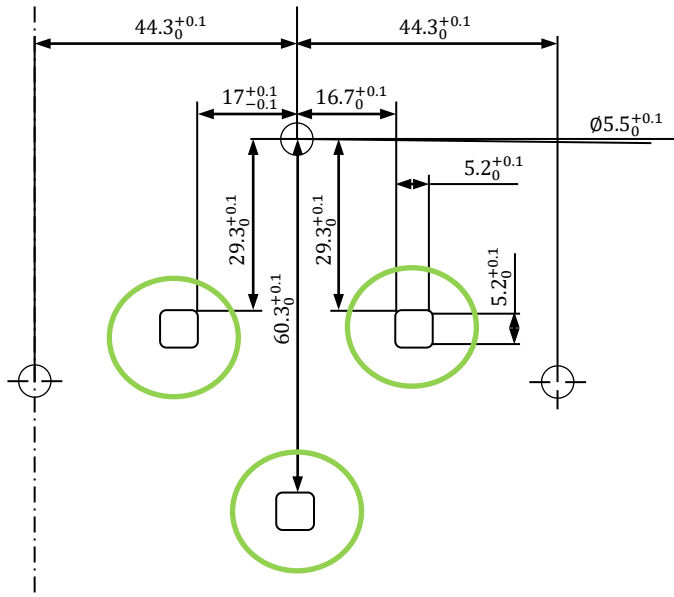

**Hole patterns for the upfitter bracket:**  
Measurement and tolerances in inches

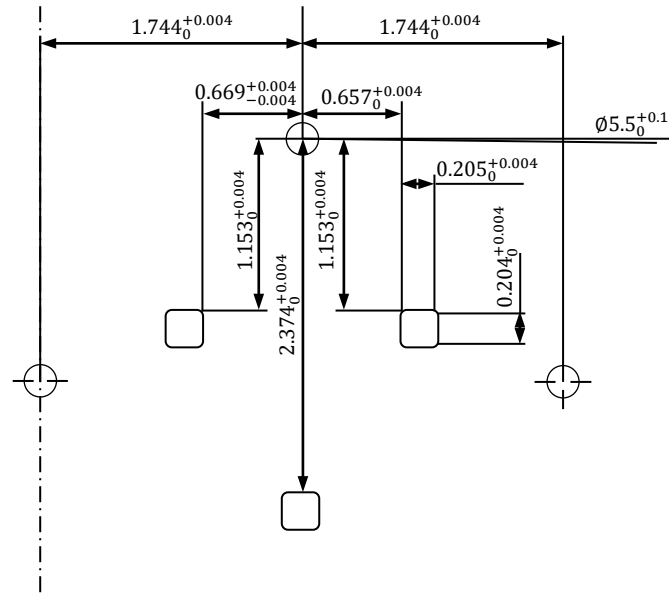

**Weight of Mercedes-Benz Parts:**

Parts	Weight (kg)	Weight (lbs.)
Sensor	0.19	0.42
Plastic Cover	0.115	0.25
Plastic Bracket	0.115	0.025

- Note: Depending on the upfitter bracket material thickness and manufacturing process, the square hole diameter might have to be adjusted (bigger diameter required).

# MY2023/24 Sprinter-Installation of Blind Spot Sensor (J1V)

## Box/Body dimensions

### Rear Overhang (Rear axle to end of box/body)

Codes	Rear Overhang (mm)	Rear Overhang (in)
O97	1700 mm ± 100 mm	66.9 in ± 4 in
O98	1900 mm ± 100 mm	74.8 in ± 4 in
O99	2100 mm ± 100 mm	82.7 in ± 4 in
OA1	2300 mm ± 100 mm	90.6 in ± 4 in
OA2	2500 mm ± 100 mm	98.4 in ± 4 in

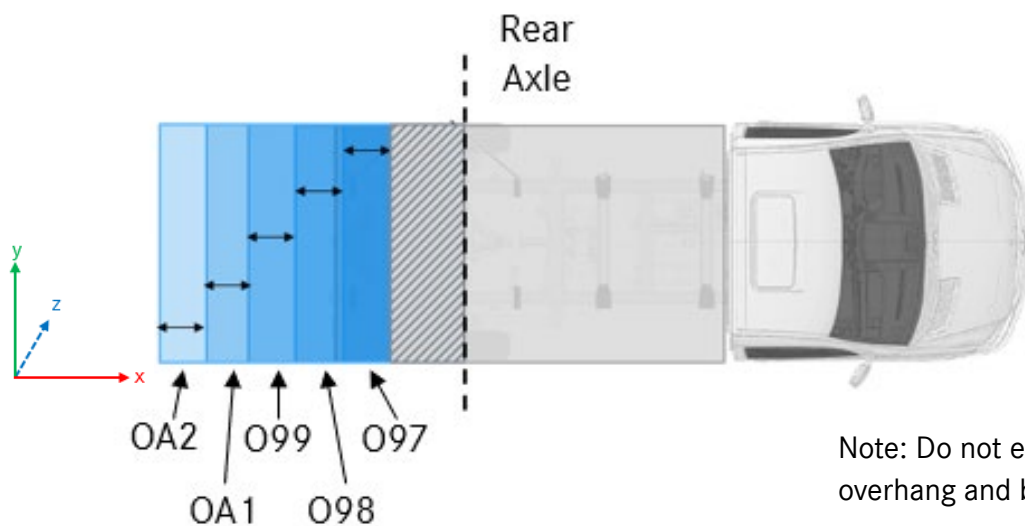

Note: Do not exceed maximum permissible vehicle overhang and box width as defined in the BEG.

### Vehicle Width

Codes	Vehicle Width (mm)	Vehicle Width (in)
O94	2150 mm ± 50 mm	84.65 in ± 1.97 in
O95	2250 mm ± 50 mm	88.58 in ± 1.97 in
O96	2350 mm ± 50 mm	92.52 in ± 1.97 in
O9K	2450 mm ± 50 mm	96.46 in ± 1.97 in

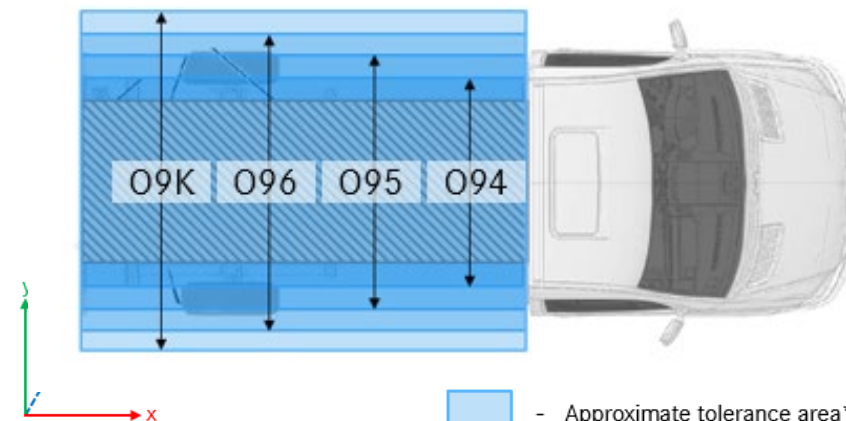

- Approximate tolerance area\*\* for provided aftermarket codes.

\*\*The provided drawing is not to scale. Please rely on your own measurement tools to determine body size and sensor location

# MY2023/24 Sprinter – Installation of Blind Spot Sensor (J1V)

## Sensor mounting dimensions for height

### Radar sensor mounting height above ground

Codes	Height (mm)	Height (in)
O8K	350 mm ± 50 mm	13.8 in ± 2 in
O8L	450 mm ± 50 mm	17.7 in ± 2 in
O8M	550 mm ± 50 mm	21.7 in ± 2 in
O8N	650 mm ± 50 mm	25.6 in ± 2 in
O8O	750 mm ± 50 mm	29.5 in ± 2 in
O8P	850 mm ± 50 mm	33.5 in ± 2 in
O8Q	950 mm ± 50 mm	37.4 in ± 2 in
O8R	1050 mm ± 50 mm	41.3 in ± 2 in
O8S	1150 mm ± 50 mm	45.3 in ± 2 in

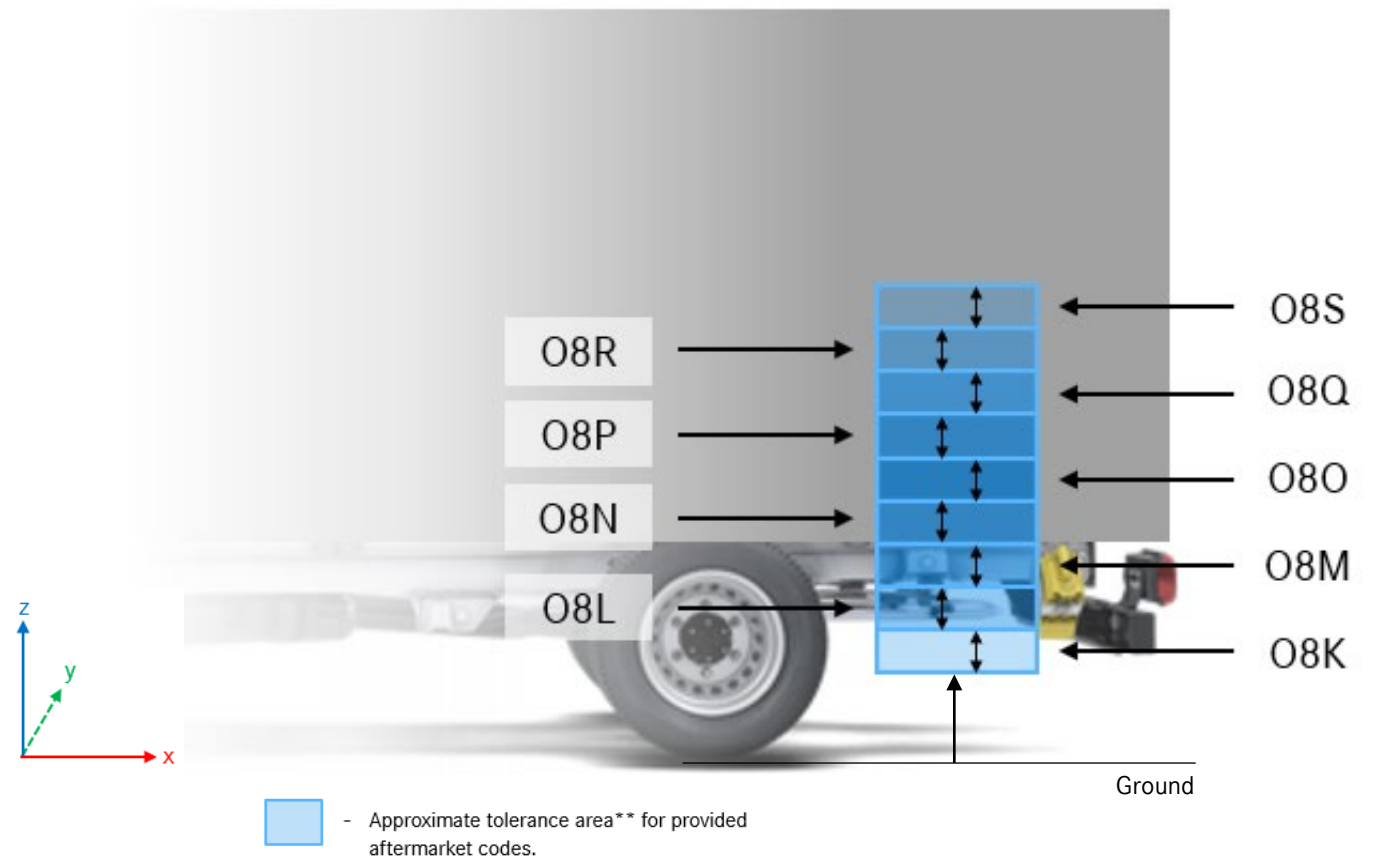

\*\*The provided drawing is not to scale. Please rely on your own measurement tools to determine body size and sensor location

# MY2023/24 Sprinter – Installation of Blind Spot Sensor (J1V)

## Sensor mounting dimensions for distance from rear axle

### Radar sensor mounting x-distance to the rear axle

Codes	X- distance to rear axle (mm)	X- distance to rear axle (in)
O7K	100 mm ± 100 mm	3.9 in ± 4 in
O7L	300 mm ± 100 mm	11.8 in ± 4 in
O7M	500 mm ± 100 mm	19.7 in ± 4 in
O7N	700 mm ± 100 mm	27.6 in ± 4 in
O7O	900 mm ± 100 mm	35.4 in ± 4 in
O7P*	Addition of 1000 mm	Addition of 39.4 in
O7Q*	Addition of 2000 mm	Addition of 78.7 in

\* O7P and O7Q are supplementary codes to be used in combination with another code (i.e. if the distance between the sensor and the rear axle is 1500 mm, then apply codes O7M + O7P, 500 mm + 1000 mm)

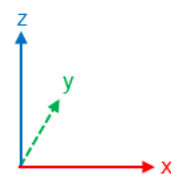

- Approximate tolerance area\*\* for provided aftermarket codes.

\*\*The provided drawing is not to scale. Please rely on your own measurement tools to determine body size and sensor location

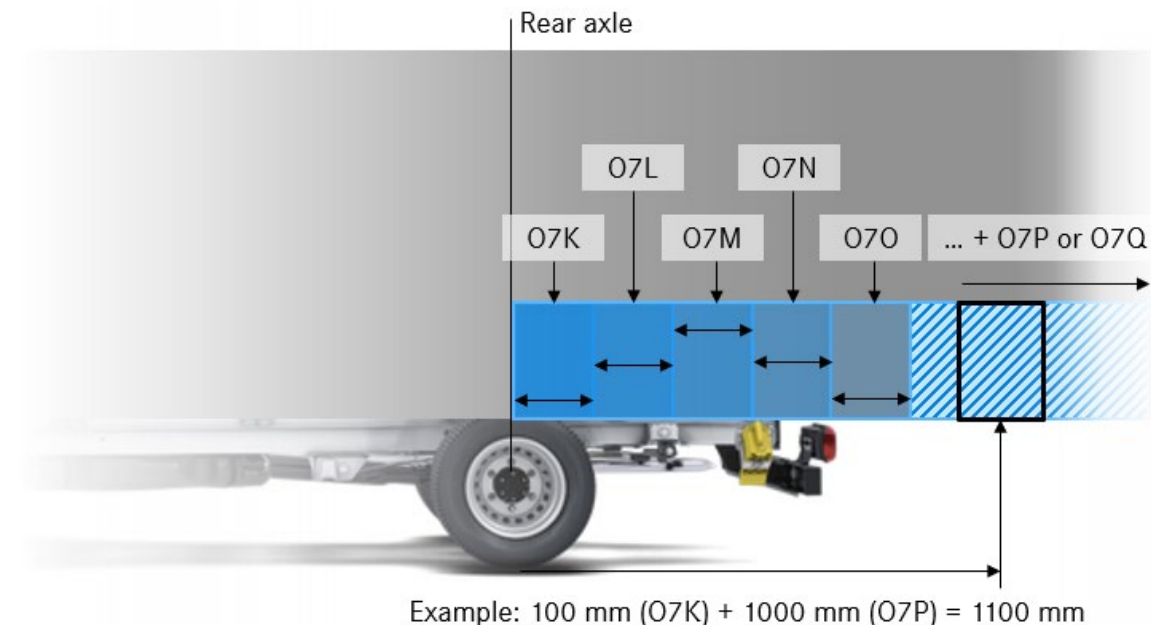

Note: Do not exceed maximum permissible vehicle overhang as defined in the BEG.